

The Graphical Process Design (GPD) of the Debt Services Process.

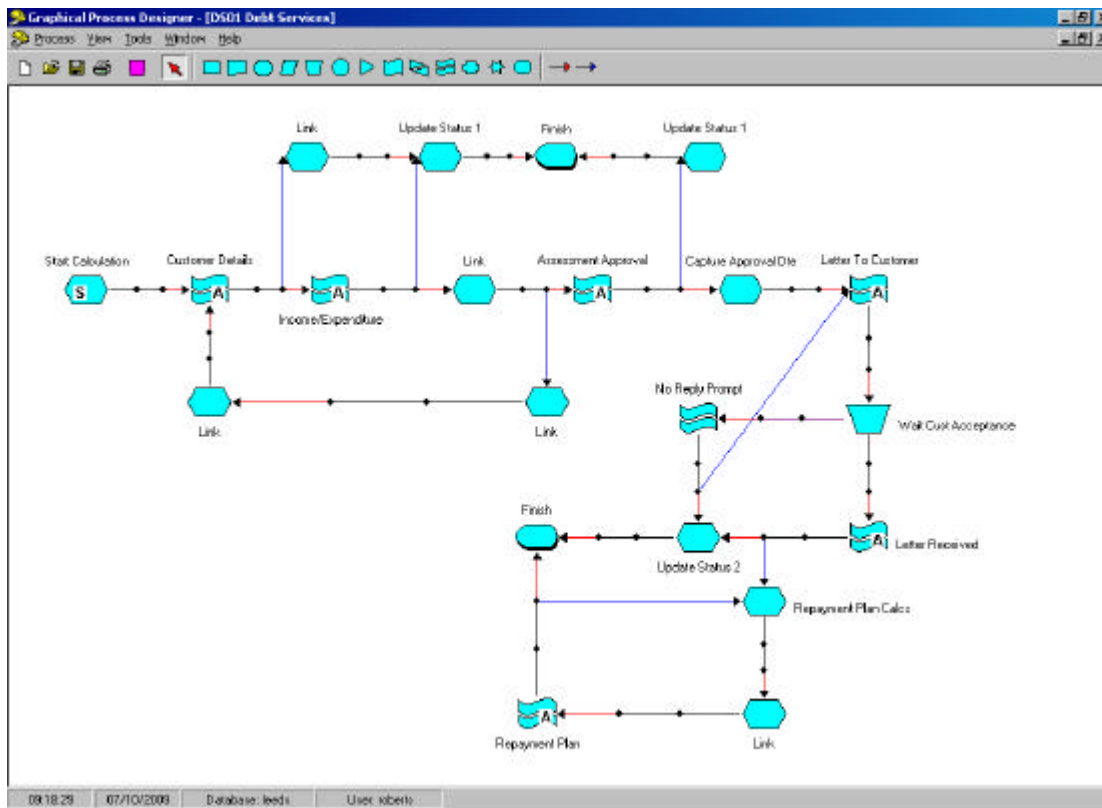

Open up a browser and enter the URL <http://www1.procession.co.uk/debtservices>

You will be presented with the login page

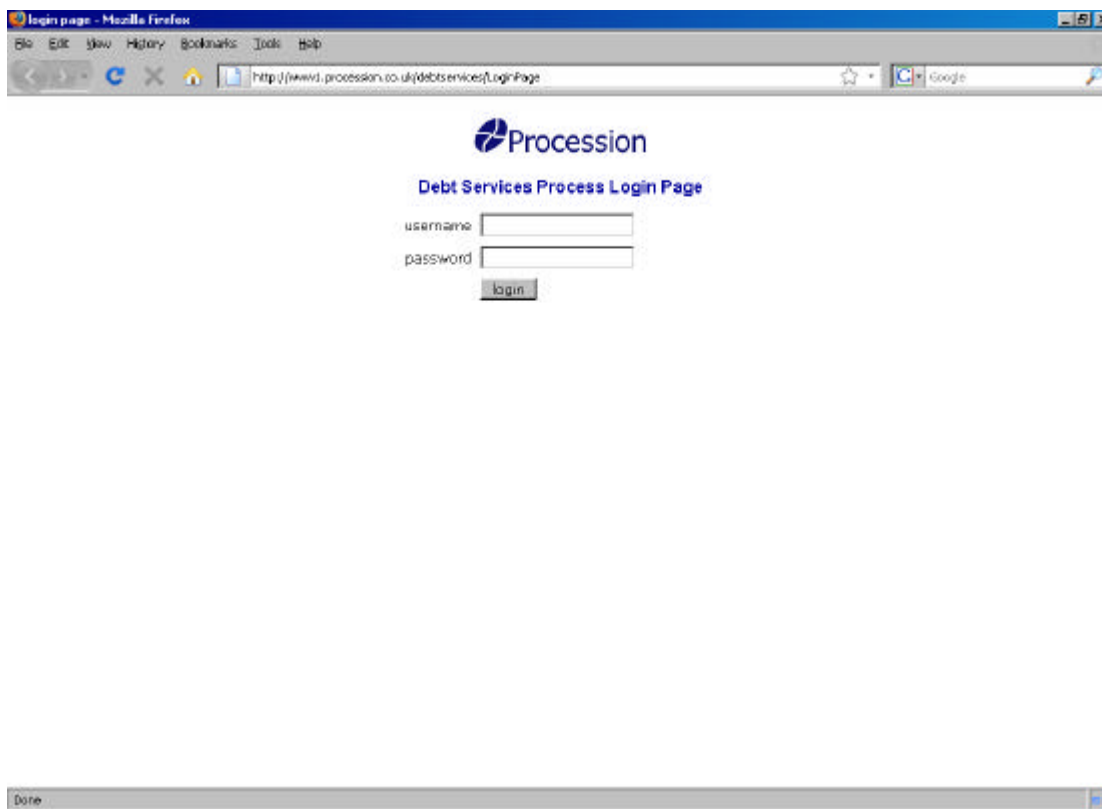

Enter the following details

User name = roberts
Password = Password1

and click "login"

You will be presented with the login page options

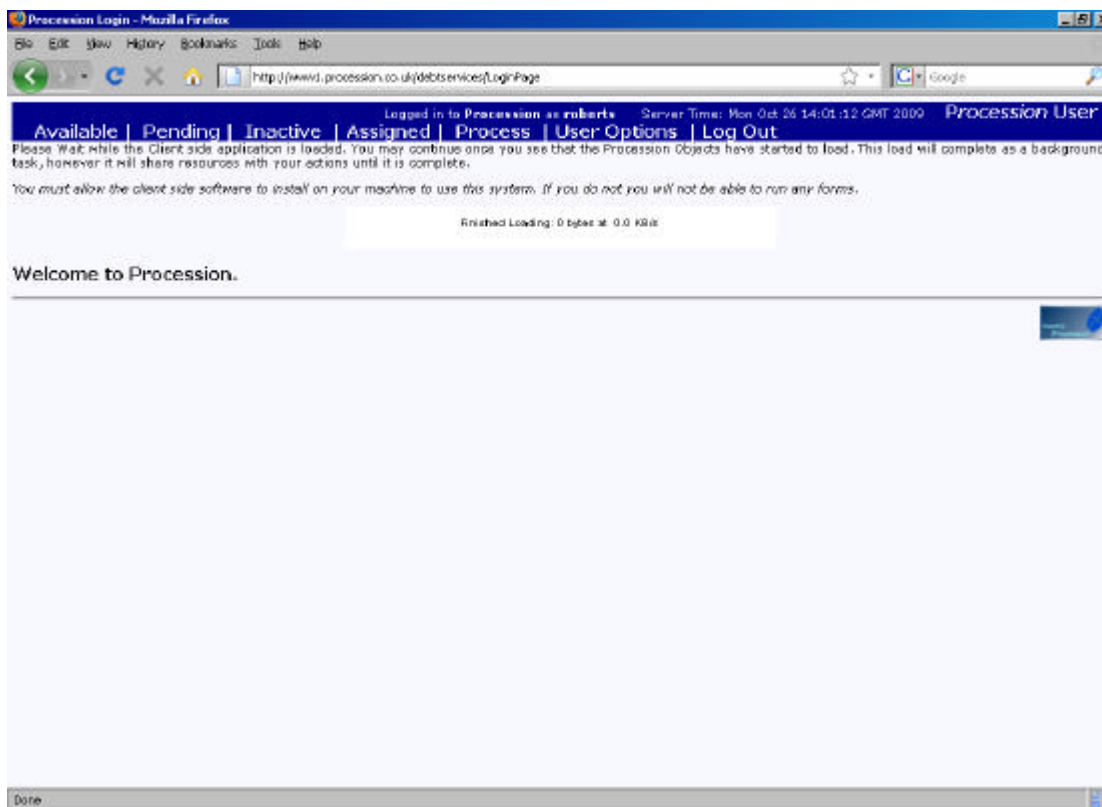

Click "Process"

You will be presented with the process tray. Click on the row and then click "Start Run..." box.

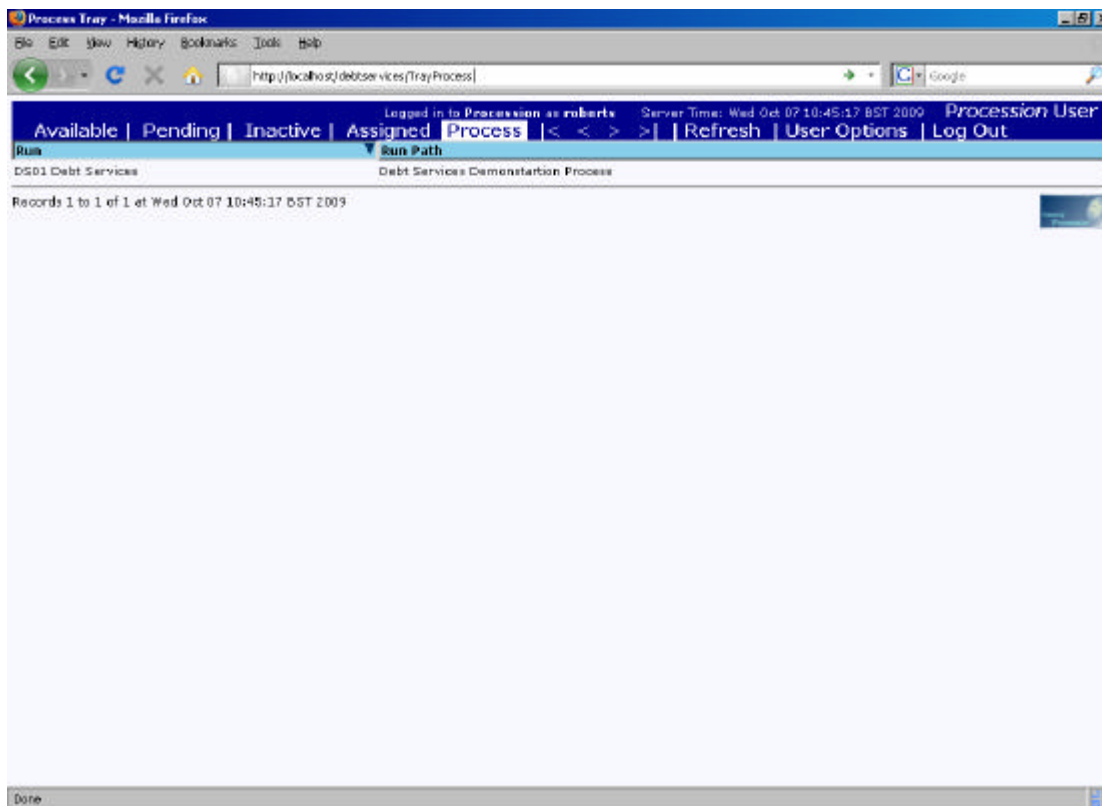

You will then proceed to screen DS1.00 – Customer Details
Enter a name and address.

Click “Cancel” to close the form without saving any changes (does not move to next task)
Click “Close” to close the form and save any changes (does not move to next task)
Click “OK” to complete the form, saves any changes and moves to the next task.

Navigation options are:
Continue To Assessment
Cancel Run

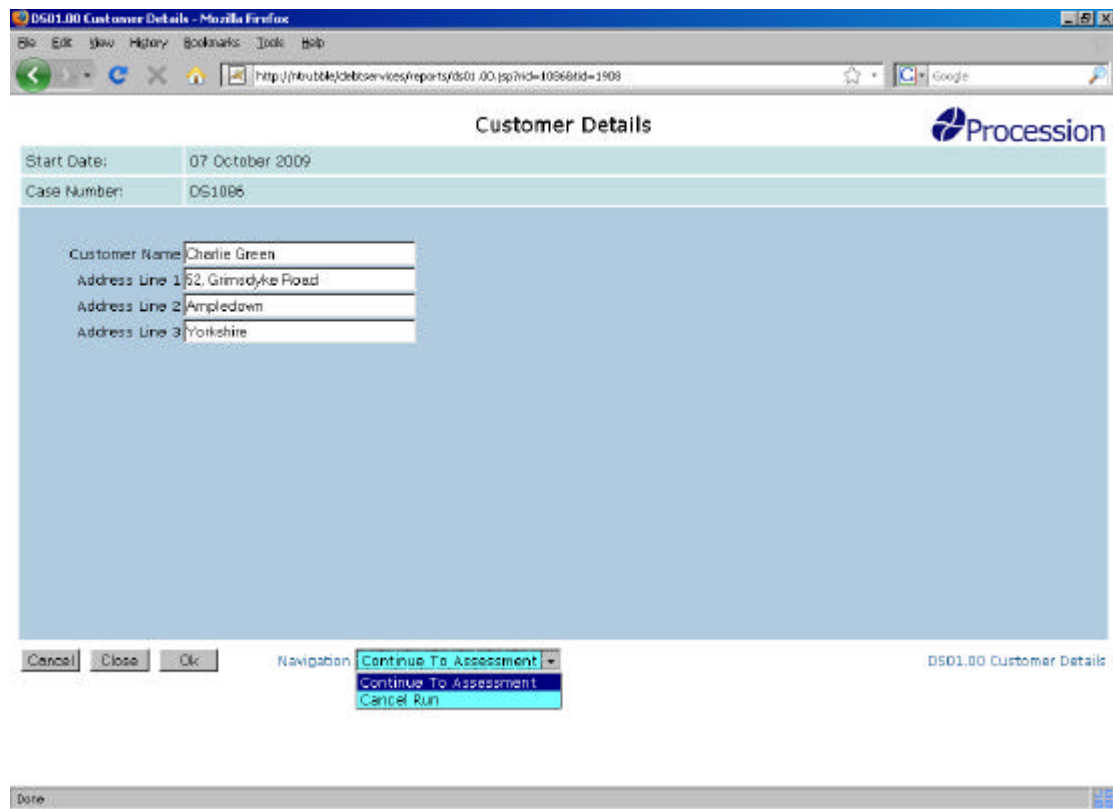

You will then proceed to screen DS1.01 – Assessment Income/Expenditure

Click the “Plus” button above either grid to add a new record, enter details and the amount. Click outside the amount field to update the totals

Navigation options are:

Send For Approval

Return To Previous Form

Cancel Run

“Cancel”, “Close”, “Ok” buttons operate as per form DS1.00

The screenshot shows a web browser window titled "DS1.01 Assessment/ Liability - Mozilla Firefox". The address bar shows the URL: http://hrubtts/ds1services/reports/ds01_01.jsp?rid=1056&id=1909. The page title is "Assessment Income/Expenditure" and the ProceSSION logo is visible in the top right corner.

Form fields at the top:

- Start Date: 07 October 2009
- Case Number: DS1086
- Customer Name: Charlie Green

Two data grids are displayed:

Monthly Income Details

Income Type	Amount
Salary	2500.00
Investments	475.00
Other Income	1200.00
Total: 4175.00	

Monthly Expenditure Details

Expenditure Type	Amount
Mortgage	3500.00
Car Loan	1000.00
Credit Card	600.00
Other Hire Purchase	575.00
Total: 5675.00	

At the bottom, there are buttons for "Cancel", "Close", and "Ok". A "Navigation" dropdown menu is open, showing options: "Send For Approval" (highlighted), "Return To Previous Form", and "Cancel Run". The text "DS1.01 Assessment/ Liability" is visible in the bottom right corner of the page.

If “Send For Approval” has been selected and “Ok” clicked the process will disappear from this user and will then appear in the Managers assigned tray for their approval.

You will now need to log out and log back on

User name = grahamb
Password = Password1

You will be presented with the login page options

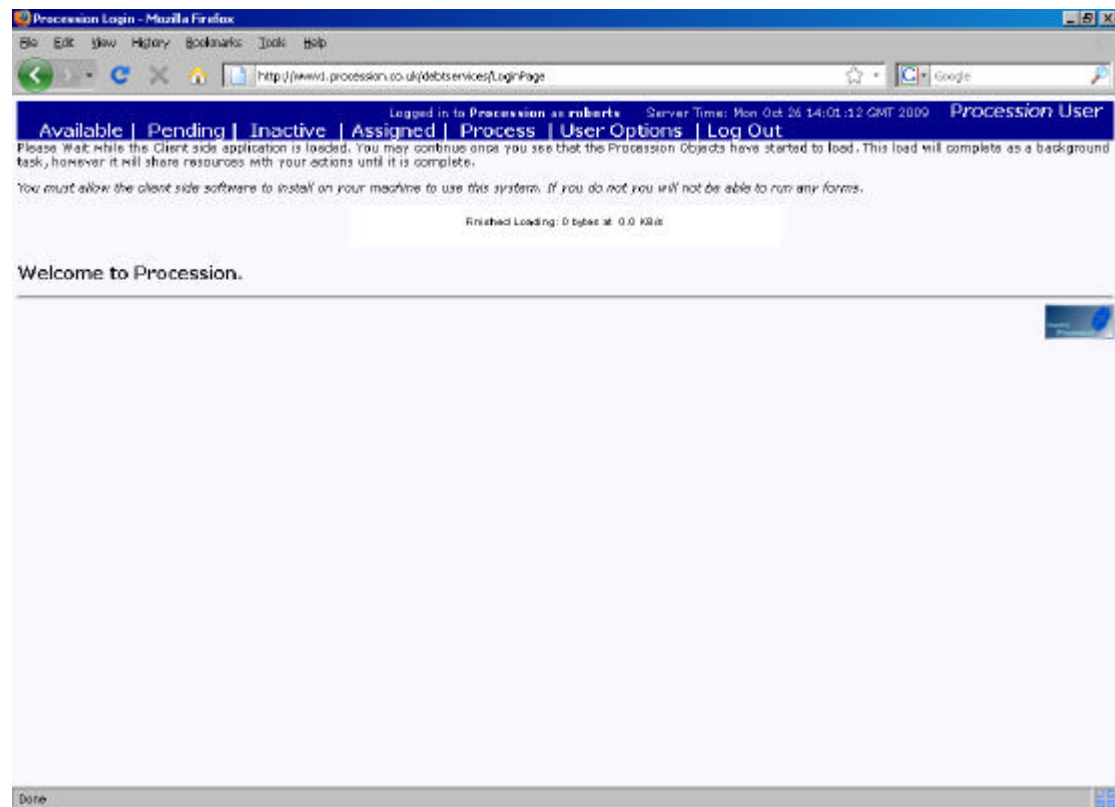

Click "Assigned"

The process will be sitting in the new users assigned tray. Click on the row and click on the "Run" option.

You will now see screen DS1.02 – Assessment Approval

Navigation options are:

Approved

Rejected

“Cancel”, “Close”, “Ok” buttons operate as per form DS1.00

If “Rejected” is selected the demonstration process will finish.

DS1.02 Assessment Approval - Mozilla Firefox

http://hrubtts/obosevices/reports/ds01_02.jsp?rid=1066&id=1911

Assessment Approval

Procession

Start Date:	07 October 2009
Case Number:	DS1006
Customer Name:	Charlie Green

Details of assessment displayed here

Total Income	4175.00
Total Expenditure	5675.00

Managers Decision:

Approved
Rejected

Cancel Close Ok

DS1.02 Assessment Approval

Done

If “Approved” has been selected and “Ok” clicked the process will disappear from this user and will then appear in the Administrators assigned tray for their action.

(You will need to log out and log back on)

User name = roberts

Password = Password1

Click “Assigned”

The process will be sitting in the users assigned tray. Click on the row and click on the “Run” option.

You will now see screen DS1.03 – Send Acceptance Letter

Click “Ok” the process will move to the Pending Tray. It has been set up to come out of the pending tray in approximately five minutes to demonstrate missing a deadline.

DS1.03 Send Acceptance Letter - Mozilla Firefox

http://hrubble/obeservices/reports/ds01_03.jsp?wid=10868&id=1913

Send Acceptance Letter

ProceSSION

Start Date:	07 October 2009
Case Number:	DS1006
Customer Name:	Charlie Green

**** Online template editing and letter generation ****

**** When letter has been sent process sits in the pending tray ****

Total Income	4175
Total Expenditure	5675

Managers Decision **Approved**

Cancel Close Ok

DS1.03 Send Acceptance Letter

Date

First time through do not do anything other than switch to the pending tray view. After a few minutes (up to 5) hit the F5 key to refresh. The task should disappear from the pending tray and re-appear in the assigned tray. Activate as before

You will now see screen DS1.05 – No Reply To Acceptance Letter

Navigation options are:

Send Reminder Letter

Cancel Run

“Cancel”, “Close”, “Ok” buttons operate as per form DS1.00

If “Cancel Run” is selected the demonstration process will finish.

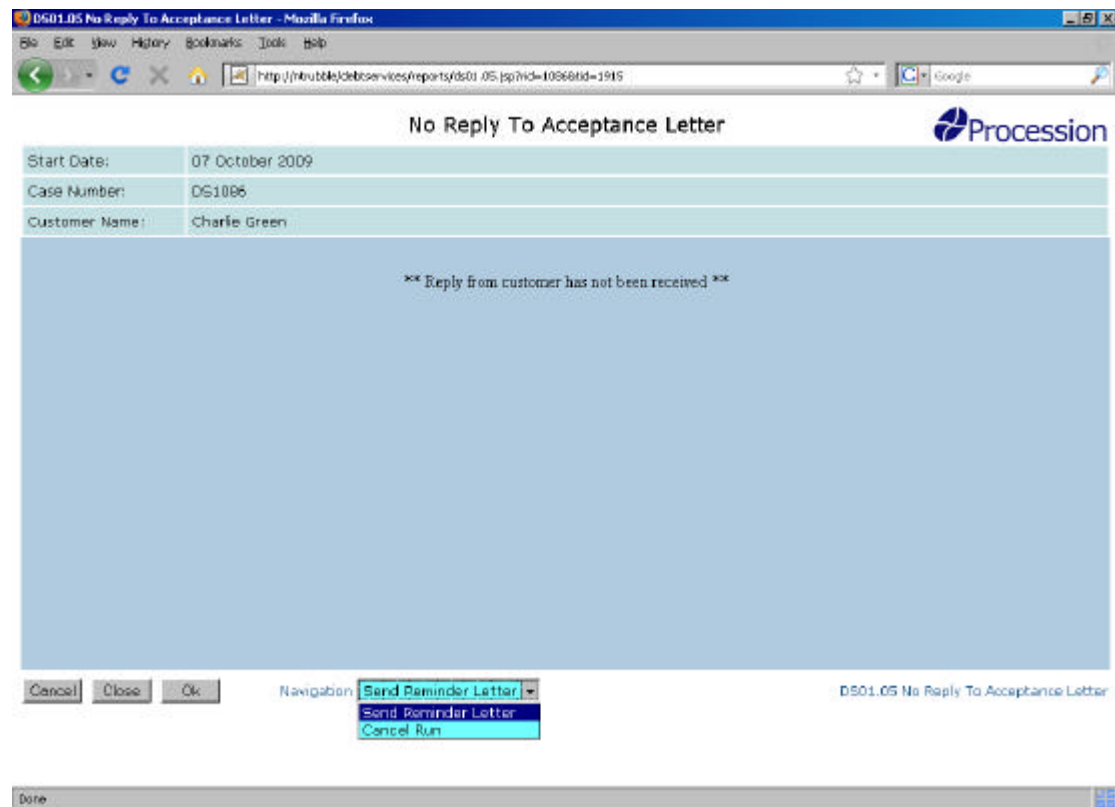

If “Send Reminder Letter” has been selected and “Ok” clicked the process will loop back to form DS1.03 – Send Acceptance Letter

Click “Ok” the process will move to the Pending Tray. This time go straight to the Pending Tray and fetch the process out of the Pending tray, this would be in response to receiving the acceptance letter from the customer within the allocated time.

You will now see screen DS1.04 – Reply To Acceptance Letter

Navigation options are:

Continue To Repayment Plan

Customer Declines - Cancel Run

“Cancel”, “Close”, “Ok” buttons operate as per form DS1.00

If “Customer Declines - Cancel Run” is selected the demonstration process will finish.

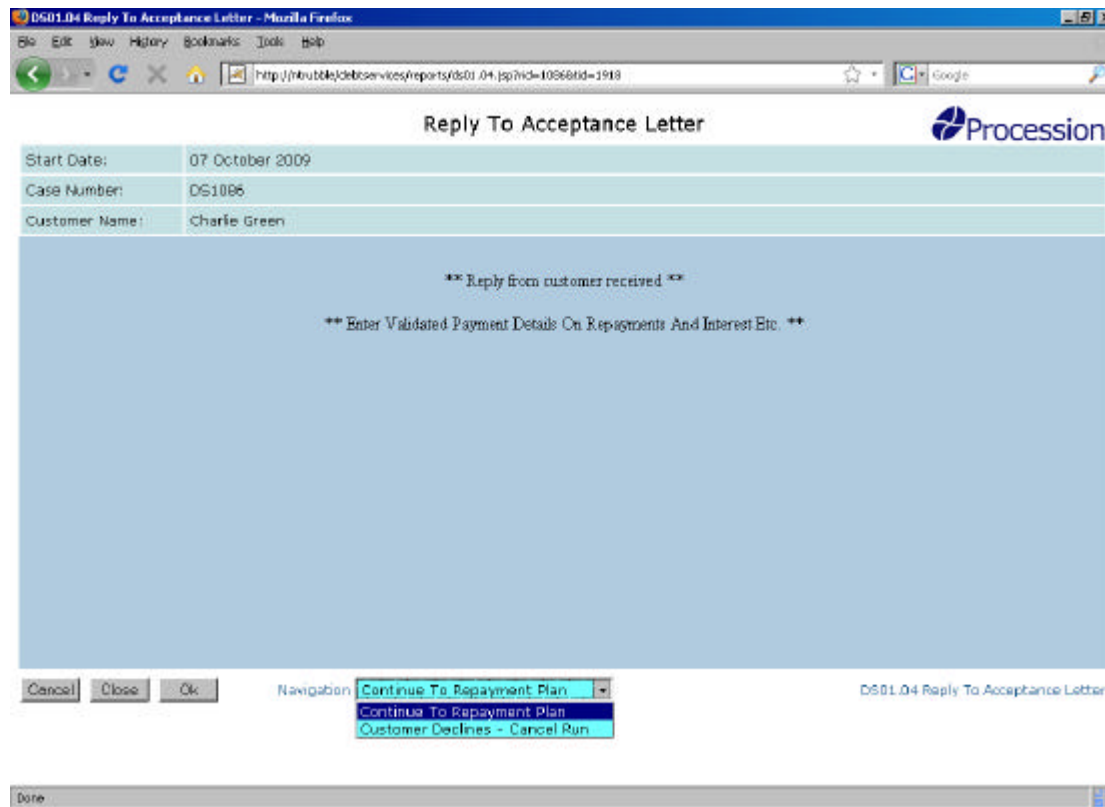

If "Continue To Repayment Plan" has been selected and "Ok" clicked the process will proceed to form DS1.06 – Repayment Plan

Navigation options are:

Recalculate Repayment Plan

Finish Demonstration

"Cancel", "Close", "Ok" buttons operate as per form DS1.00

You can enter a different "Fee Rate" select "Recalculate Repayment Plan" and click "Ok" the process will loop through the "Repayment Plan Calcs" and come back to this form with the updated scheduled plan amounts.

DS1.06 Repayment Plan - Mozilla Firefox

http://hrubt44.debeservices/reports/ds01_06.jsp?rid=1036&tid=1921

Repayment Plan

Procession

Start Date: 07 October 2009
Case Number: DS1006
Customer Name: Charlie Green

Expenditure Type	Amount	Plan Amount
1 Mortgage	3500.00	2817.40
2 Car Loan	1000.00	662.11
3 Credit Card	600.00	397.27
4 Other Hire Purchase	575.00	300.72
Totals	5675.00	3757.50

Fee Rate % Management Fee 417.50
(enter new % rate & re-calculate) Fee + Plan 4175.00
Total Income 4175.00

Navigation: **Recalculate Repayment Plan**
Recalculate Repayment Plan
Finish Demonstration

Done

General

Instead of logging off and on when demonstrating the process, the alternative is to open up two instances of a browser (this has to be Internet Explorer as it loses the session identifier) and log in as the two separate users and switch between browser instances at the appropriate time of the demo.